



TL-3724 USER`S MANUAL



TL elektronik
Airport, Building 125, Hradec Kralove
503 41, Czech Republic

© Copyright 2003-2006
TL elektronik
All Rights Reserved

Except as expressly provided below, no part of this manual may be downloaded, transmitted, copied, reproduced, disseminated or stored in any storage medium, for any purpose without the express prior written consent of the TL elektronik company. Address your questions about the technical information to TL elektronik. Other information about sale, distribution should be directed to our exclusive distributors (see World Distributor list on our website).

Producer's address:
TL elektronik Inc.
Airport, Building 125,
503 41 Hradec Kralove, Czech Republic
Fax: +420 49 548 23 94 E-mail: info@tl-elektronic.com
Website Address: www.tl-elektronic.com

***Please, send your e-mail address to customer@tl-elektronic.com
to receive the latest information about the software upgrade.***

*Send your ideas to innovation@tl-elektronic.com.
We will evaluate your suggestion and provide an update.*

Record of revision

Revision	Revision date	Description	ECO#	Insertion date	By
A	1/5/03	Initial Release	---		
B	1/7/04	Language and design update	0001		
C	1/7/05	Inst. / Sens. accuracy added	0002		

Window is registered trademark of Microsoft Corporation.
All trademarks and registered trademarks are acknowledged.
ScheckK® is registered trademark of TL elektronik.
iFamily® is registered trademark of TL elektronik.
sModern® is registered trademark of TL elektronik.

All information in this User's manual is subject to change without prior notice.

TABLE OF CONTENTS

1. GENERAL DESCRIPTION	
1.1. Introduction.....	1-1
1.2. Instrument Description.....	1-1
1.3. Technical Specifications.....	1-2
1.4. Limited Warranty.....	1-3
2. INSTALLATION	
2.1. Introduction.....	2-1
2.2. Rack Consideration.....	2-1
2.3. Installation of Accessories.....	2-1
2.4. Mounting Rack Dimensions.....	2-2
3. SYSTEM INTERCONNECT	
3.1. Pin Function List.....	3-1
3.2. TL-3724 Interconnects.....	3-2
3.3. TL-3724 Connector Location.....	3-3
4. NAV-MENU DESCRIPTION	
4.1. How to Control Instrument via NAV-MENU.....	4-1
5. INSTRUMENT SETUP	
5.1. First Instrument Turn-on.....	4-1
5.2. Main Set-up Functions' Description.....	5-1
6. OPERATION MANUAL	
6.1. After-installation Check.....	6-1
6.2. Engine Name.....	6-2
6.3. Long-term Memory of Maximum Measured Values.....	6-3
6.4. „READY“ to Take-off.....	6-3
6.5. „OVER“ Limit Message.....	6-3
6.6. „SERVICE MESSAGE“.....	6-3
6.7. Deleting „SERVICE MESSAGE“.....	6-4
6.8. „LOW POWER“ Message.....	6-4
7. SchecK® DESCRIPTION	
7.1. Method of SchecK® for Storing into Memory.....	7-1
8. OPERATION MANUAL	
8.1. Instrument Configuration.....	8-1
8.2. Defined Limit Values.....	8-1
8.3. Other Configuration.....	8-1

1. GENERAL DESCRIPTION

1.1. INTRODUCTION

This manual describes the physical, mechanical and electrical features and functions of the TL-3724 Combined Engine Instrument.

1.2. EQUIPMENT DESCRIPTION

The TL-3724 is a complete engine monitor for measuring all quantities of an engine.

The TL-3724 facilitates seeking the cause of an engine default or damage, with use of the SchecK® method for storing the measured values into the memory.

The TL-3724 checks all measured values at two levels - for a warning and an alarm limit signalization. When the alarm warning has been activated, the instrument will display a Service message after the next turn-on to inform the user on the exceeded some value.

The instrument incorporates a 2,000-line long-term memory and SchecK memory (see page 5-1) for storing the measured values at 0.1 to 60 second sample rate.

The TL-3724 incorporates a Memory / Info button for displaying the maximum measured values and other information.

It is possible to download the measured values from the instrument via the serial cable RS-232c into your PC.

 **The placement of the values on the display, as well as setting the quantity you want to show, can be changed at any time with use of the Windows program delivered with the instrument.**

 **The producer of the engine instrument and its distributor reserve the right not to announce the correct code as this code helps to decide whether the guarantee can be applied.**

1.3. TECHNICAL SPECIFICATIONS

The producer guarantees all stated technical parameters only when the instrument is installed by an authorized service or an aircraft works.

1.3.1 Physical characteristics

Width	85mm (3.346 inches)
Height	85mm (3.346 inches)
Depth	102mm (4.015 inches) including connectors
Panel hole	80mm (3.149 inches) diameter
TL-3724 Weight	0.4 kg (0.88 lbs)
TL-3724 Harness	0.05 kg (0.11 lbs)

1.3.2 General Specifications

Operating Temperature Range	-20°C to +70°C
Humidity	95% non-condensing
Altitude Range	4600 metres max.
Power Range	10.0 to 32.0 Volts
Max. Signalization	30 Volts, 1 Ampere
Power Consumption	0.25 Ampere @ 14 VDC
Backlight Consumption	ext. input 0.25 Ampere @ 14 VDC
Measuring accuracy	±1% @ 25°C
Vibration	5 to 500 Hz
Sample Rate (LCD Refresh)	1 second

1.3.3 Long-term Memory and Communication

Storing Rate	0.1 to 60 seconds user selectable
Memory Capacity	Scheck® method
Stored Values	8 parameters from LCD
Data Saved Endurance	30 years
Rolling Memory life-time	50 000 hours @ 1 second storing rate
Communication	RS-232c
Communication Speed	38400 bps

1.3.4 Sensor Parameters / Measured Range / Accuracy / Resolution

3724-01 - EGT Temperature	thermocouple K -35 °C to +1200 °C / ±5°C / 1°C
3724-16 - EGT probe (Rotax)	thermocouple K -35 °C to +1150 °C / ±5°C / 1°C
3724-02 - CHT Temperature	thermocouple J -35 °C to +900 °C / ±2°C / 1°C
3724-04 - W/O sens. (Rotax)	VDO black/yelow isolator 0 to +160 °C / ±3°C / 1°C
3724-14 - W/O sens. (Jabiru)	VDO gray isolator 0 to +160 °C / ±3°C / 1°C
3724-03 - Oil (Rotax 2-stroke)	399S thermistor 0 to 110 °C / ±4°C / 1°C
3724-15 - W/O probe (Rotax)	PT-100 -20 to +240 °C / ±2°C / 1°C
3724-05 - Pressure (Rotax)	VDO 29/12 0 to 10 bars / ±0.2 Bars / 0.1 Bars
3724-13 - Pressure sens. (Jabiru)	ELT 0 to 5 bars / ±0.2 Bars / 0.1 Bars
3724-06 - Pressure sensor	Honeywell 0 to 10 bars / ±0.1 Bars / 0.1 Bars
Voltage	Internal 10.0 to 16.0 V / ± 0.2 Volts / 0.1 Volts
Low RPM voltage	±6 to ±50 VAC / 500 to 9999 rpm / ±10 / 10 rpm
High RPM voltage	±25 to ±80 VAC / 500 to 9999 rpm / ±10 / 10 rpm
Positive RPM only	+6 to +60 VDC / 500 to 9999 rpm / ±10 / 10 rpm
	(VAC can be applied)
Engine Hours	0 to 9999.5 hours / ±2 seconds @ 1 hour

1.4. LIMITED CONDITIONS

1.5. LIMITED WARRANTY

The TL elektronik company warrants this product to be free from defects in materials and manufacture for three years from the date of purchase. TL elektronik will, at its sole option, repair or replace any components that fail in normal use. Such repairs or replacement will be made at no charge to the customer for parts or labour. The customer is, however, responsible for any transportation costs. This warranty does not cover failures due to abuse, misuse, accident or unauthorized alteration or repairs.

THE WARRANTIES AND REMEDIES CONTAINED HEREIN ARE EXCLUSIVE AND IN LIEU OF ALL OTHER WARRANTIES EXPRESS OR IMPLIED OR STATUTORY, INCLUDING ANY LIABILITY ARISING UNDER ANY WARRANTY OF ENCHANT ABILITY OR FITNESS FOR A PARTICULAR PURPOSE, STATUTORY OR OTHERWISE. THIS WARRANTY GIVES YOU SPECIFIC LEGAL RIGHTS, WHICH MAY VARY FROM STATE TO STATE.

IN NO EVENT SHALL TL ELEKTRONIC BE LIABLE FOR ANY INCIDENTAL, SPECIAL, INDIRECT OR CONSEQUENTIAL DAMAGES, WHETHER RESULTING FROM THE USE, MISUSE, OR INABILITY TO USE THIS PRODUCT OR FROM DEFECTS IN THE PRODUCT. SOME STATES DO NOT ALLOW THE EXCLUSION OF INCIDENTAL OR CONSEQUENTIAL DAMAGES, SO THE ABOVE LIMITATIONS MAY NOT APPLY TO YOU.

To obtain warranty service, call the TL elektronik Customer Service (+420 49 548 23 92) for a returned merchandise tracking number. The unit should be securely packaged with the tracking number clearly marked on the outside of the package and sent freight prepaid and insured to a TL elektronik warranty service station. A copy of the original sales receipt is required as the proof of purchase for warranty repairs. TL elektronik retains the exclusive right to repair or replace the unit or software or offer a full refund of the purchase price at its sole discretion.

SUCH REMEDY SHALL BE YOUR SOLE AND EXCLUSIVE REMEDY FOR ANY BREACH OF WARRANTY.

1.6. LIMITED OPERATION

**This product is not TSO approved as a flight instrument, therefore, the manufacturer will not be held responsible for any damage caused by its use.
The TL elektronik company is not responsible for any possible damage of an engine or its destruction caused by default measurement of the instrument.**

2. INSTALLATION

2.1 INTRODUCTION

Careful planning and consideration of the suggestions in this section are required to achieve the desired performance and reliability from the TL-3724.

2.2 RACK CONSIDERATION

Plan a location that gives the pilot complete and comfortable access to the entire keypad and that is plainly visible from the pilot's perspective. Check that there is adequate depth for the rack in the instrument panel. A place away from heating vents or other sources of heat generation is optimal.

2.3 INSTALLATION OF ACCESSORIES

Make sure that the sensor connection corresponds with the set configuration of the instrument according to the Instrument Configuration. In other case, contact an authorized distributor for the correct sensor setting. Connection of sensors and other parts must be done properly to avoid any damage.

 Connect the cables into the connector and use the connector cover. Secure the incoming leads to prevent their effect on the connector in the vertical direction.

Mounting Rack Dimension

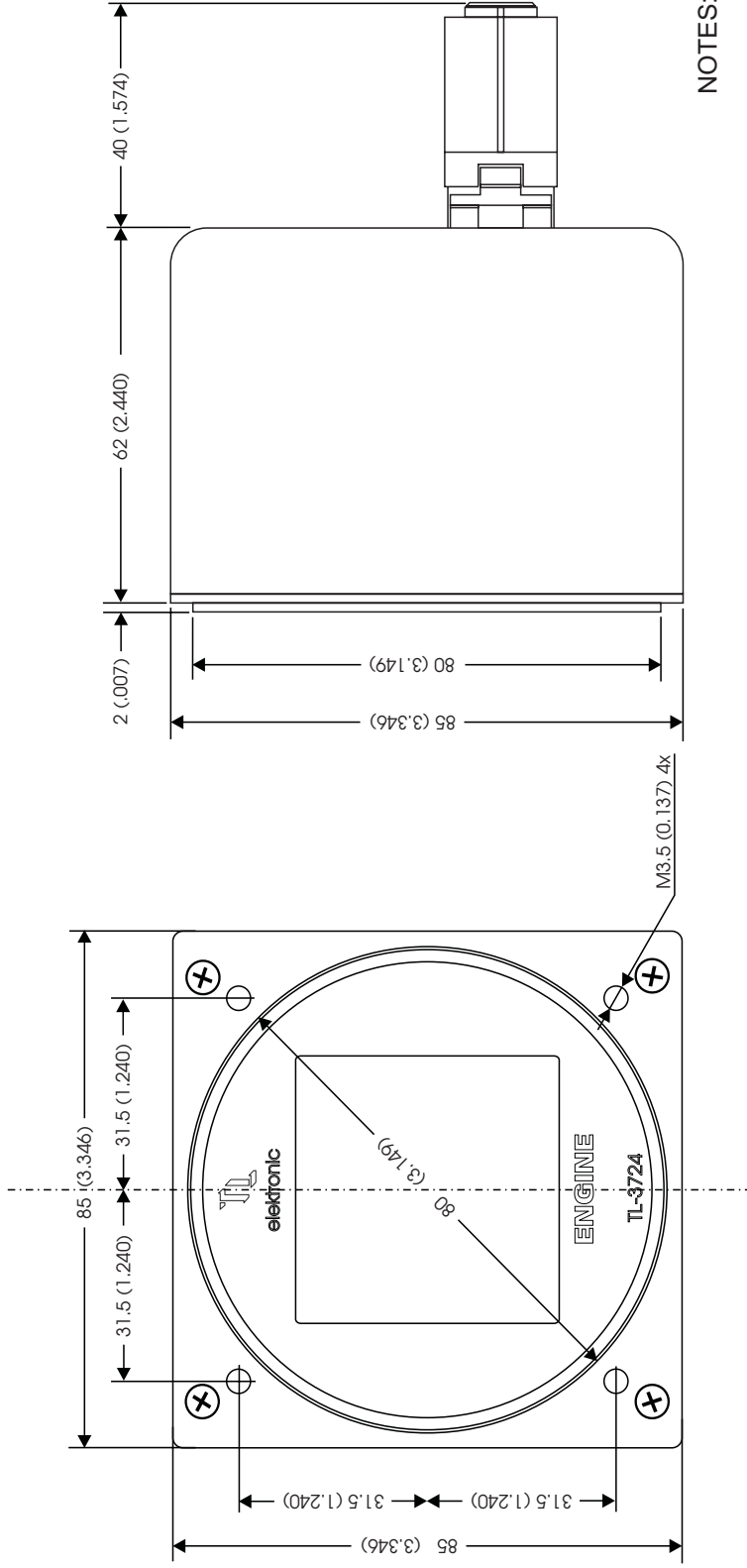

NOTES:

1. Dimension: mm (INCH)
2. Unit weight: 0.4 kg (0.88 lbs)
3. Mounting Rack & Hardware weight: 0.05 kg (0.11 lbs)

Figure 1. Rack Dimension

3.1 PIN FUNCTION LIST

Pin	Pin Name	I/O
1	Flow sensor input	In
2	Power +12 Volts for fuel flow and oil pressure sensor	Out
3	Pressure sensor input	In
4	Ground for fuel flow and oil pressure sensor	--
5	Alarm signalization	Out
6	Ground for RS-232 communication	--
7	RS-232 IN	In
8	RS-232 OUT	Out
9	Memory / Info button input	In
10	Ground for Memory / Info button	--
11	iFamily® communication ISCL	I/O
12	iFamily® communication ISDA	I/O
13	Thermocouple No.1 - positive input	In
14	Thermocouple No.1 - negative input	In
15	RPM High voltage input	In
16	RPM Positive voltage input	In
17	Thermocouple No.2 - positive input	In
18	Thermocouple No.2 - negative input	In
19	RPM Low voltage input	In
20	Ground for RPM sensor	--
21	Thermocouple No.3 - positive input	In
22	Thermocouple No.3 - negative input	In
23	Display backlight - source for Jump	Out
24	Display backlight - input	In
25	Thermocouple No.4 - positive input	In
26	Thermocouple No.4 - negative input	In
27	Aircraft power	In
28	Aircraft ground	--
29	Thermocouple No.5 - positive input	In
30	Thermocouple No.5 - negative input	In
31	Oil temperature or IAT sensor	In
32	Ground for oil temperature or IAT sensor	--
33	Thermocouple No.6 - positive input	In
34	Thermocouple No.6 - negative input	In
35	Water temperature or OAT sensor	In
36	Ground for water temperature or OAT sensor	--

Accessories Interconnect

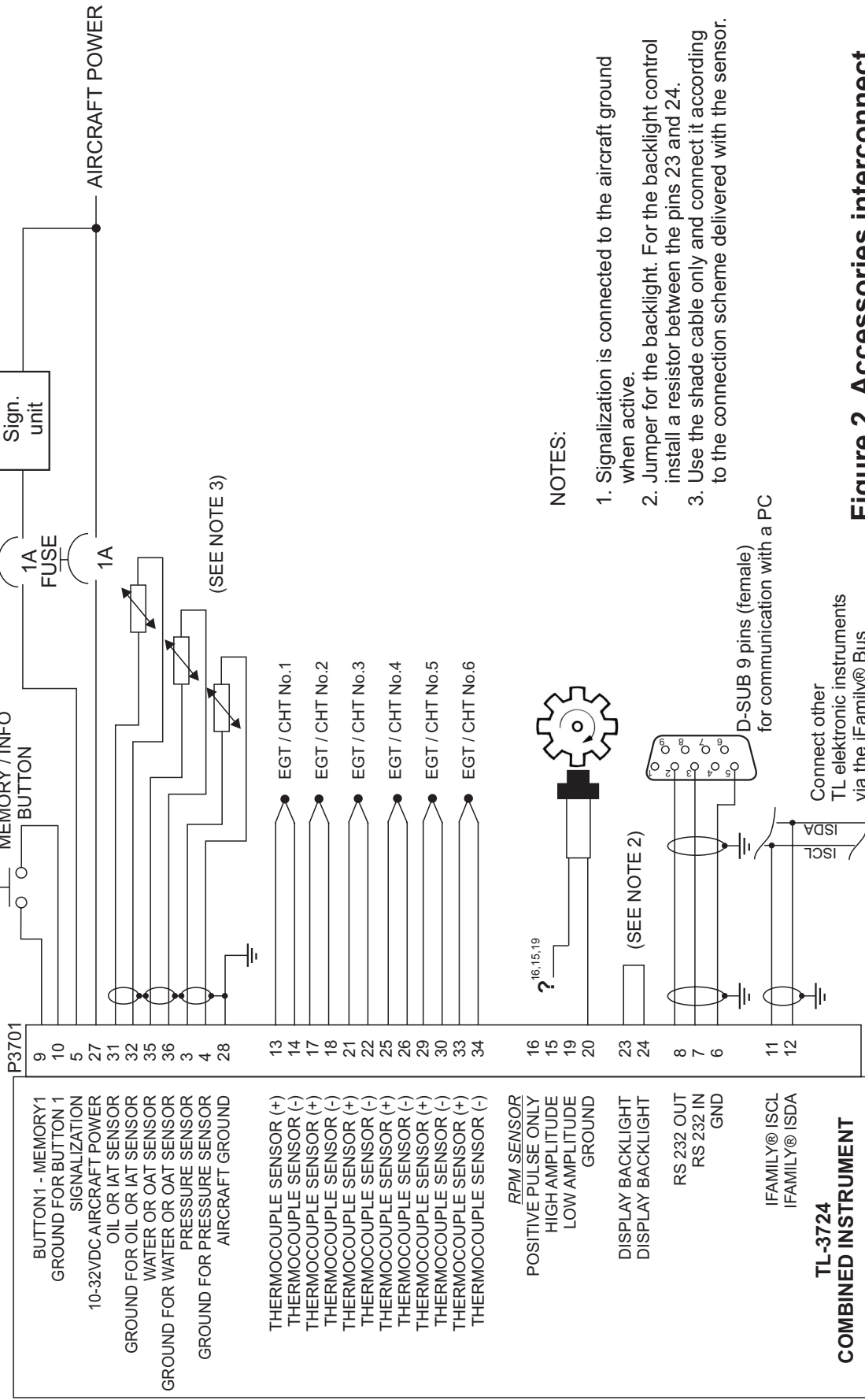

NOTES:

1. Signalization is connected to the aircraft ground when active.
2. Jumper for the backlight. For the backlight control install a resistor between the pins 23 and 24.
3. Use the shade cable only and connect it according to the connection scheme delivered with the sensor.

Figure 2. Accessories interconnect

Other Accessories Interconnect

<p>POWER FOR FLOW SENSOR OUTPUT FROM FLOW SENSOR GROUND FOR SENSOR</p>	<p>(Note. 1)</p> <p>2 1 4</p>	<p>FLOW SENSOR</p>
<p>POWER FOR PRESSURE SENSOR OUTPUT FROM PRESSURE SENSOR GROUND FOR SENSOR</p>	<p>(Note. 1)</p> <p>2 3 4</p>	<p>ACTIVE THREE-WIRE PRESSURE SENSOR</p>
<p>POWER FOR RPM SENSOR OUTPUT FROM RPM SENSOR GROUND FOR RPM SENSOR</p>	<p>(Note. 1)</p> <p>2 16 20</p>	<p>ACTIVE THREE-WIRE ROTATION SPEED SENSOR</p>

**TL-3724
 COMBINED INSTRUMENT**

NOTES:

1. Use the shade cable only and connect it according to the connection scheme delivered with the sensor.

Figure 3. Other Accessories interconnect

Rear view of connector plate

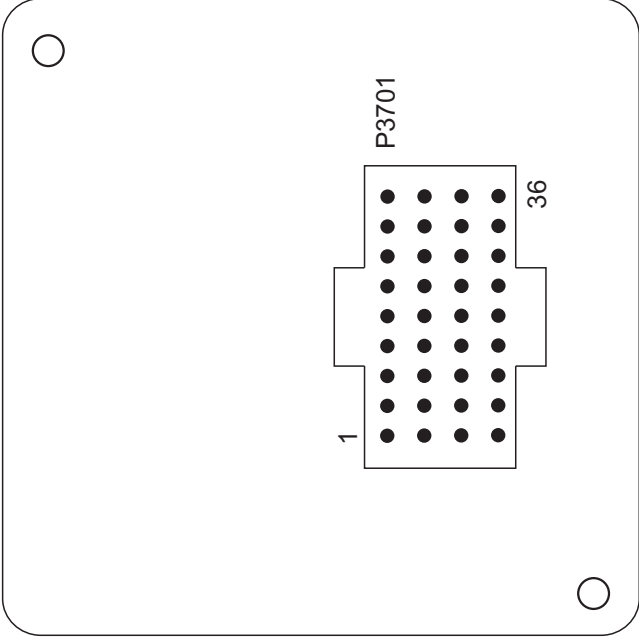

NOTES:

- 1. Use delivered connector black cover for cable protect.

Figure 5. Connectors locate

4. NAV-MENU DESCRIPTION

4.1 How to Control Instrument via NAV-MENU

There are black labels on the display.
The function of the left label can differ in each menu.

The left label is for the Left button.

The left label is affiliated to the User/Memory button. Before pressing a button, read the information on the label.

The right label provides information.

This label is not affiliated to any button and provides information only. Usually, you can find an instruction on this label such as „WAIT“ for waiting for an operation to be completed or „OFF“ for turning the instrument off.

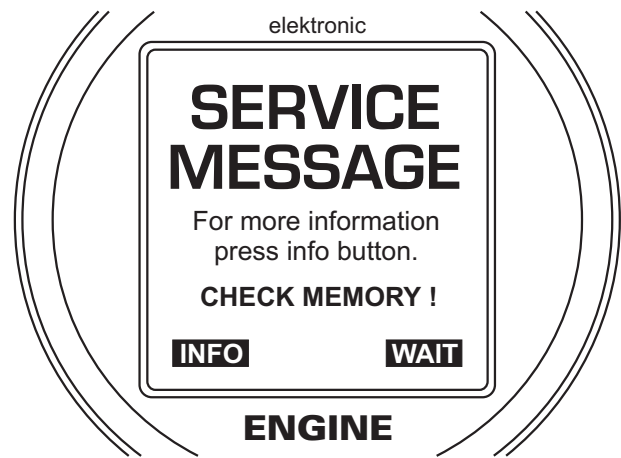

5. INSTRUMENT SETUP

5.1 First Instrument Turn-on

Before the Combined Instrument starts to indicate, you must do the basic setting of quantities, contrast, units, etc.

The set-up can be done only via PC. This set-up must be completed to continue.

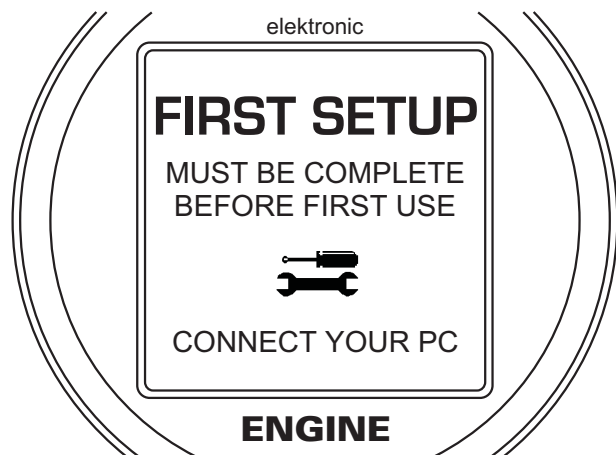

5.2 Main Set-up Functions' Description

The table of the instrument configuration steps is shown below (Initial - firmware version 5.2).

0	PASSWORD	Enter your password.
1	CHANGE LOGO	Enter a new logo, which will show after turning the instrument on.
2	QUANTITIES	Select the quantities that will show on the display in the position given by the drop-down menus' order.
3	INPUT	Set for the measured quantity EGT or CHT the number of the input to which the particular sensor is connected.
4	TYPE OF SENSOR	Select the sensor type for the particular measured quantity.
5	WARNING LIMIT	Set the Warning limit for the particular measured quantity.
6	ALARM LIMIT	Set the Alarm limit for the particular measured quantity.
7	S/N	Enter the series number of your engine.
8	TYPE OF ENGINE	Select the engine type.
9	DISPLAY MESSAGE	Enter the name of your engine, which will show after turning the instrument on.
10	PULSE PER REV.	Set the number of pulses corresponding with one engine rotation.
11	TOTAL TIME	Enter the initial engine hours.
12	TEMPERATURE UNIT	Select your local unit for temperature.
13	PRESSURE UNIT	Select your local unit for pressure.
14	FLOW K-FACTOR	Set the K-FACTOR for the fuel flow sensor.
15	FLOW AVERAGE	Set the interval of averaging the instant fuel consumption in seconds (the averaging interval will ensure a more stable reading).
16	FLOW UNITS	Select your local unit for fuel flow.
17	BUTTON CLEAR	Select the mode of deleting the „SERVICE MESSAGE“ ENABLE = deleting by pressing the button and turning the instrument on, DISABLE = deleting is possible via PC only.
18	READY OIL	Set the oil temperature at which your engine is hot for the take-off.
19	READY FOR RPM	Set the rotation speed at which the message „COLD ENGINE“ will be stored into the memory in case of exceeding this rotation speed while the oil temperature is lower than the one set in the „READY OIL“.
20	MIN. OIL LIMIT	Set the Warning limit for the minimum oil pressure.
21	MIN. OIL ALARM	Set the Alarm limit for the minimum oil pressure.
22	MIN ACTIVATE RPM	Set the RPM at which counting the time will be started and the set values will start to be checked.
23	DISPLAY CONTRAST	Set the display contrast level.
24	VOICE WARNING	Enable or disable voice warning into your headphones. (Only with use of our Intercom TL-2424 or Voice Module)



All information on this page is subject to change without prior notice. Download the latest version of the manual from www.tl-elektronic.com and compare with you version of firmware.

6. OPERATION MANUAL

6.1 After-installation Check

After the installation, check the correctness of all connected inputs and turn the instrument on. After turning the instrument on, check the correctness of the measured values. All set values will show on the display. If the symbol [---] shows, it means that a sensor might not be connected or might not work.

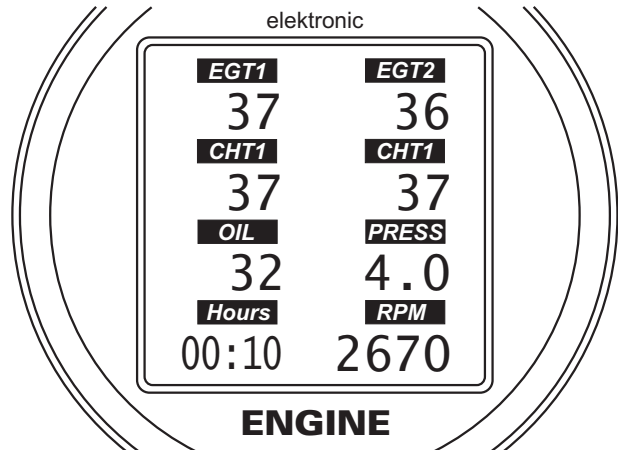

- ⚠** If the instrument has not been purchased as a part of the engine, the configuration is required. Do the configuration with use of the Windows program delivered with the instrument.
- ⚠** If some of the measured values is out of range (the symbol [---] shows on the display) or if some of the measured values is incorrect, do not start the engine! If you started the engine, the signalization of exceeding the limits might be activated, and the incorrect values would be recorded into the memory.

6.2 Engine Name

Make sure that the name of your engine is shown correctly on the display. Also check whether the correct local unit for measuring temperature in °C or °F has been set.

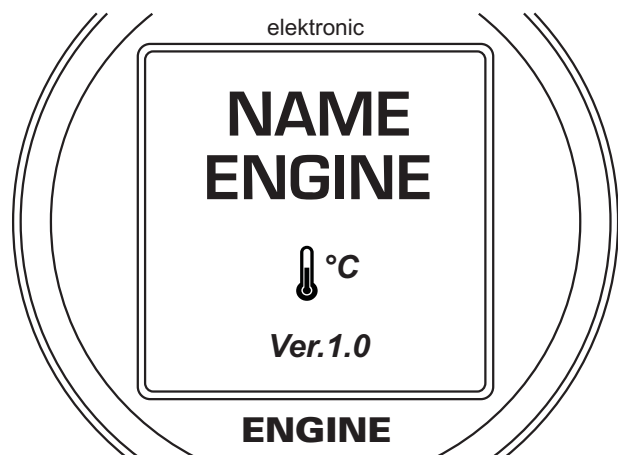

- i** The pressure units (bars or psi), as well as the fuel consumption units (litres, UK gallons or US gallons), can be found out in the Windows configuration program or in the download of the measured values.

6.3 Long-term Memory of Maximum Measured Values

After pressing the Memory / Info button, the maximum measured values of all displayed quantities will show.

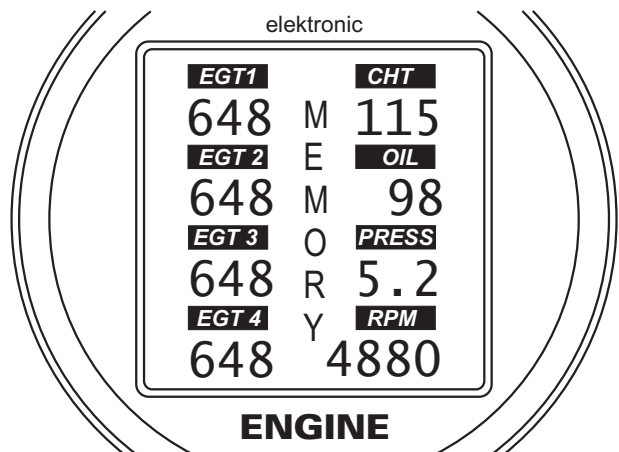

⚠ Do not manipulate, connect or disconnect the sensor while the engine is on, otherwise extremely high values could be recorded.

6.4 „READY“ to Take-Off

The „READY“ message shows when the engine has reached the operational temperature after the start-up. This message will show only if the correct temperature datum has been set.

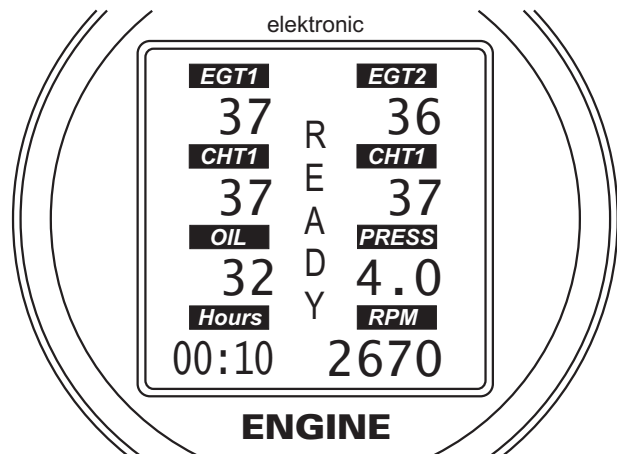

6.5 „OVER“ Limit Message

The instrument checks the measured values at two levels. The first one, Warning signalization informs the pilot by blinking on exceeding the limit and that more attention should be paid to the measured values (the yellow field). If the measured value exceeds the Alarm limit (the red field), blinking will continue and the „OVER“ message will show. After the next turn-on of the instrument, the „SERVICE“ message will show.

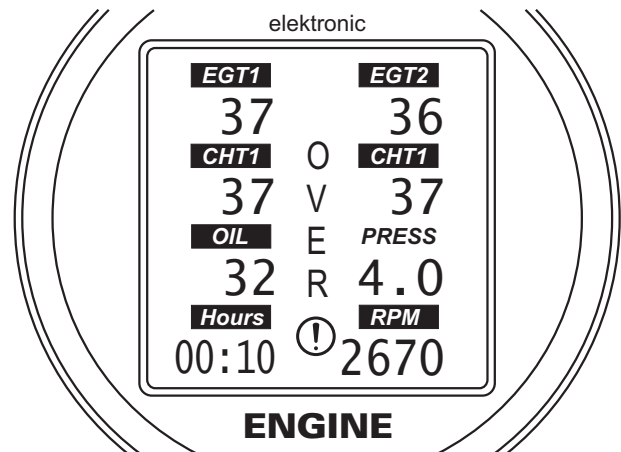

⚠ The limit value check is activated immediately after the set rotation value for the activation is reached. Only the minimum oil pressure check is activated after 5 seconds to allow the oil circuit to get pressurized.

6.6 „SERVICE MESSAGE“

If the set limit values have been exceeded, the „SERVICE MESSAGE“ shows after turning the instrument on. This information will disappear after 15 seconds and then the instrument get back to the normal measuring mode. By pressing the „INFO“ button, the pilot has to find out which measured item has been exceeded and eliminate the possible defect.

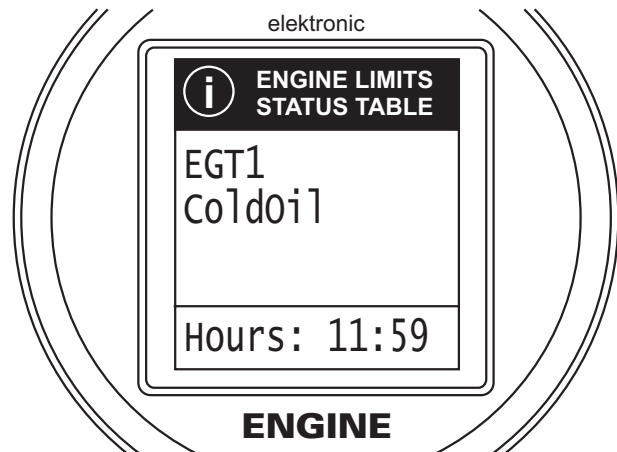

6.7 Deleting „SERVICE MESSAGE“

When deleting the „SERVICE MESSAGE“ has been enabled in the instrument via the PC control software, the „SERVICE MESSAGE“ can easily be deleted by pressing the „INFO“ button and turning the instrument on at the same time. After that the „SERVICE DELETED“ message shows on the display.

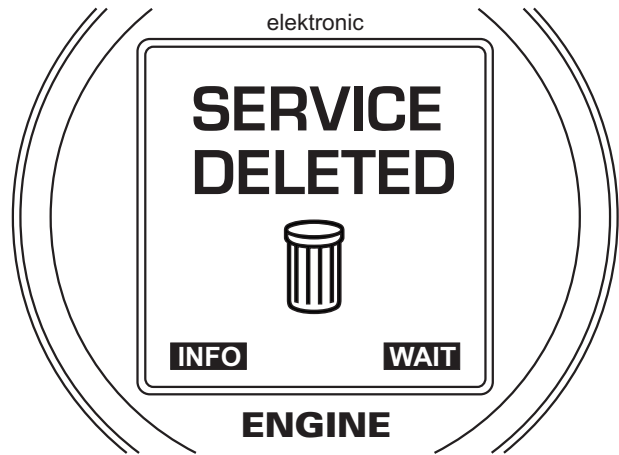

6.8 „LOW POWER“ Message

This message will show always when voltage drops under the operational limit. This may happen during the engine start up etc. In this case, wait till the instrument gets back to the normal measuring mode.

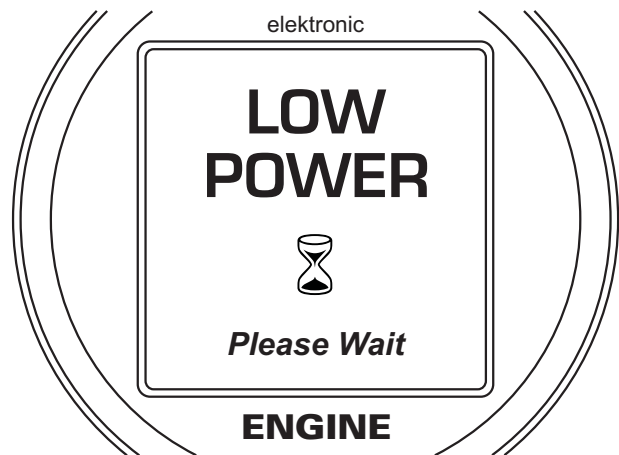

6.9 „SYSTEM ERROR“ Message

If the automatic internal circuit check found out an error in the instrument or a data integrity defect, the „SYSTEM ERROR“ message will show on the display.

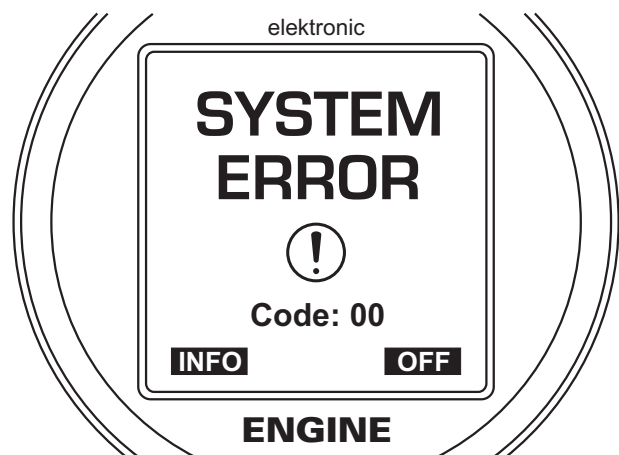

⚠ Do not try to repair the instrument yourself. Contact a distributor or the producer with the 2-digit number specifying the error.

7.1 SchecK memory description

The TL-3724 includes a 2,000 lines long-term memory and SchecK memory for storing measured values in the 0.1 to 60 second sample rate. You can download the measured data via standard PC serial cable RS-232 into Laptop or Personal Computer.

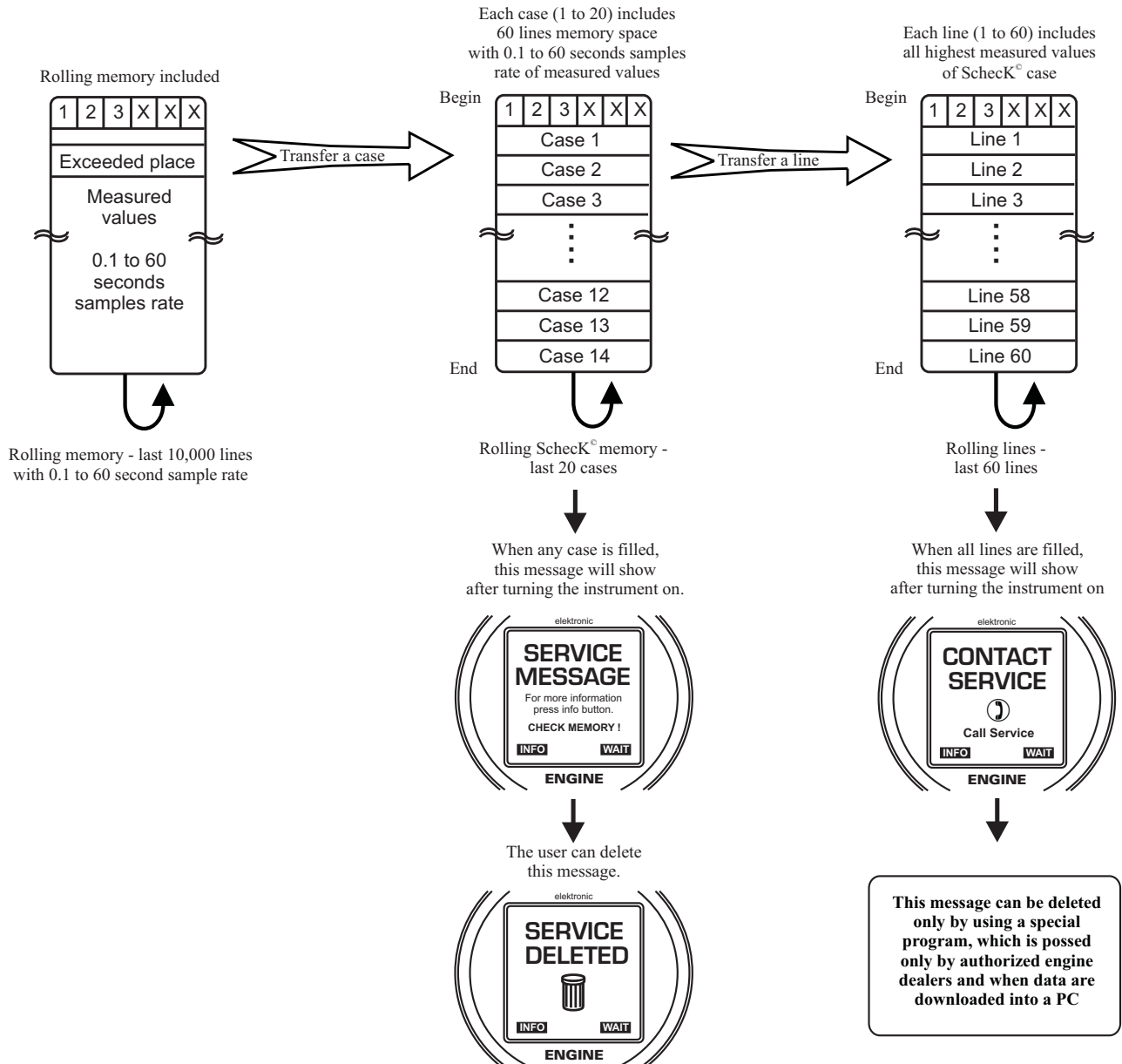

Cases 1 to 20 include the record of limit-exceeding values and engine hours, date and time referring to the moment of limit exceeding. Each case includes 60 lines.

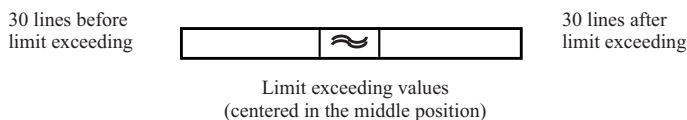

In this version it is possible to read last 20 exceeded records at total operational time.

8. INSTRUMENT CONFIGURATION

8.1 Instrument Configuration

Position on the LCD	Name of value	Type of sender	Input
1 - left first			
2 - left second			
3 - left third			
4 - left fourth			
5 - right first			
6 - right second			
7 - right third			
8 - right fourth			

8.2 Defined Limit Values

°C	°F	bar	psi	Gallons	UK	US	Litres
----	----	-----	-----	---------	----	----	--------

Position	Maximum		Minimum	
	Warning	Alarm	Warning	Alarm
1				
2				
3				
4				
5				
6				
7				
8				

8.3 Other Configuration

Engine Name:		Signalization Activate:	rpm
Engine Number:		Ready Oil Temp:	°C
Pulse p. rev.:	pulse	Max RPM to Ready Oil:	rpm
LCD Contrast:	con	K-FACTOR	value

This page intentionally left blank